

OXFORD Wire Precision Micrometer

Specially designed for measuring wire diameters 0 - 10mm. The front of the body is flat to help support the wire when measuring. With knurled thimble, ratchet stop and vernier scale barrel, all over satin chrome finish.



UKAS Calibration Service Available

See Page 612

Capacity	Resolution	Weight each	Order Code	List Price/1	Offer Price/1
0 - 10mm	0.002mm	150g	OXD-335 -2000K	£132.00	£99.00



Mitutoyo Blade Micrometers - Satin Chrome Finished Frame

Series 122

For the measurement of narrow grooves in forming tools, shaft diameters, keyways, splines, etc. The spindle is non-rotating, the anvils hardened and precision lapped. Made of forged steel the frame is fitted with heat plates. The sleeve and thimble are satin finished.

Blade thickness: 0.030" (0.75mm).
Measuring depth: 0.25" (6.5mm).
Parallelism: 0.00012"/3µm up to 2"/50mm. (3+L/100)mm, (0.00012+0.00004L/4") for models over 2"/50mm.

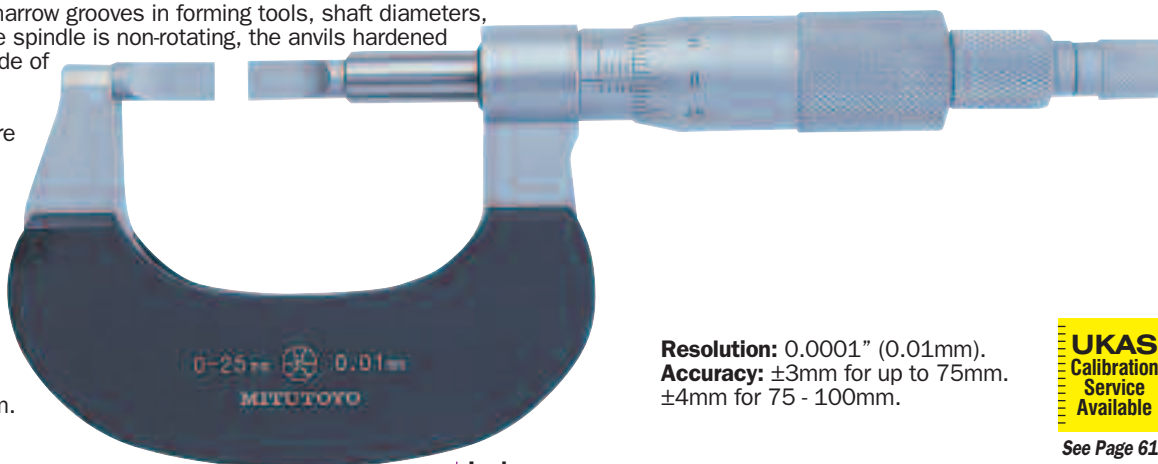

Resolution: 0.0001" (0.01mm).
Accuracy: ±3mm for up to 75mm. ±4mm for 75 - 100mm.

UKAS Calibration Service Available

See Page 612

Metric

Product Number	Range	Resolution	Weight each	Order Code	List Price/1	Offer Price/1
122-103	50 - 75mm	0.01	379g	-1382C	£196.00	£172.48

Inch

Product Number	Range	Resolution	Weight each	Order Code	List Price/1	Offer Price/1
122-125	0 - 1"	0.001"	222g	-1390S	£159.00	£139.92
122-126	1 - 2"	0.001"	270g	-1391T	£168.00	£147.84
122-127	2 - 3"	0.001"	379g	-1392V	£196.00	£172.48
122-128	3 - 4"	0.001"	439g	-1393W	£211.00	£185.68

Mechanical Tube Micrometers - Enamelled Frame

Series 115

For measuring wall thickness, collars, tubing etc. Checking dimensions from inside holes to outside edges. Measuring faces carbide tipped, anvil and spindle are hardened, precision ground and micro-lap finished.

Instrument error: ±3µm.

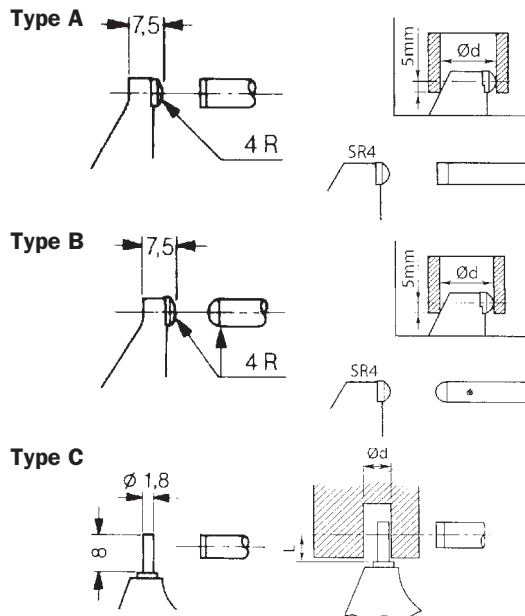
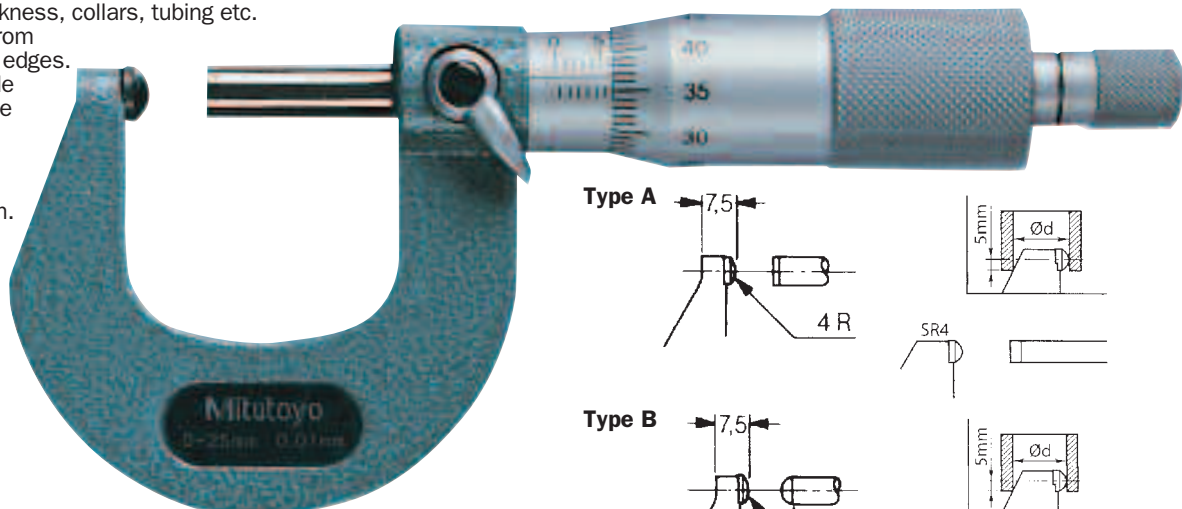

UKAS Calibration Service Available

See Page 612

Product Number	Range	Min I/D of Tube	Resolution	Weight each	Order Code	List Price/1	Offer Price/1
One Spherical Face - Type A							
115-115	0 - 25	10mm	0.01	180g	-1180A	£79.20	£69.70
115-116	25 - 50	11mm	0.01	240g	-1181B	£80.70	£71.02
115-153	0 - 1"	0.4"	0.0001"	180g	-1195M	£79.20	£69.70
Two Spherical Face - Type B							
115-215	0 - 25	10mm	0.01	180g	-1210A	£84.50	£74.36
115-216	25 - 50	11mm	0.01	240g	-1211B	£86.10	£75.77
115-253	0 - 1"	0.4"	0.0001"	180g	-1229N	£84.50	£74.36
Cylindrical Rod - Type C							
115-302	0 - 25	2mm	0.01	180g	-1235K	£82.10	£72.25

CONTRACT PRICES AVAILABLE FOR VOLUME PURCHASES