

Vernier Depth Gage

SERIES 527

FEATURES

- Base and measuring faces are hardened and micro-lapped.
- Made of hardened stainless steel.
- Optional wider extension bases are available. (up to 450mm range models)

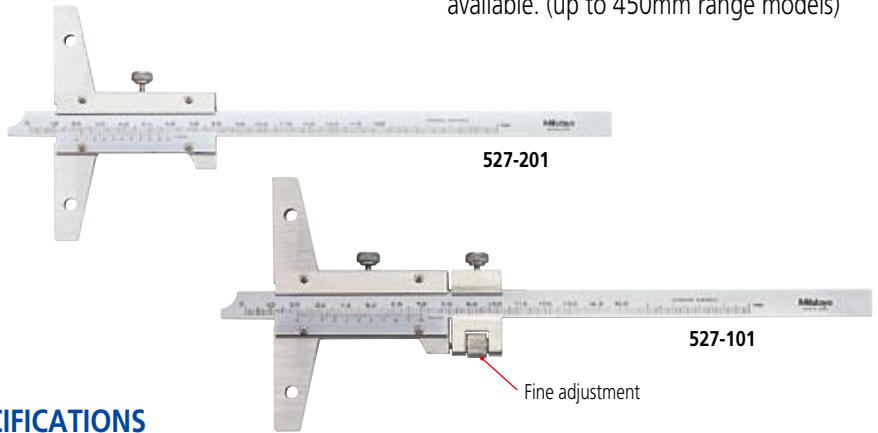

Technical Data

Accuracy: Refer to the list of specifications.
 Graduation: 0.05mm, 0.02mm or .001"

Optional Accessories

—: Extension base (see page D-55.)

SPECIFICATIONS

Metric					
Range	Order No.	Vernier reading	Accuracy	Base (W x T)	Remarks
0 - 150mm	527-201	0.05mm	±0.05mm	100 x 6.5mm	—
0 - 150mm	527-121	0.02mm	±0.03mm	100 x 6.5mm	—
0 - 150mm	527-101	0.02mm	±0.03mm	100 x 6.5mm	with fine adjustment
0 - 200mm	527-202	0.05mm	±0.05mm	100 x 6.5mm	—
0 - 200mm	527-122	0.02mm	±0.03mm	100 x 6.5mm	—
0 - 200mm	527-102	0.02mm	±0.03mm	100 x 6.5mm	with fine adjustment
0 - 300mm	527-203	0.05mm	±0.08mm	100 x 6.5mm	—
0 - 300mm	527-123	0.02mm	±0.04mm	100 x 6.5mm	—
0 - 300mm	527-103	0.02mm	±0.04mm	100 x 6.5mm	with fine adjustment
0 - 600mm	527-204	0.05mm	±0.10mm	250 x 10mm	—
0 - 600mm	527-104	0.02mm	±0.05mm	250 x 10mm	with fine adjustment
0 - 1000mm	527-205	0.05mm	±0.15mm	250 x 10mm	—
0 - 1000mm	527-105	0.02mm	±0.07mm	250 x 10mm	with fine adjustment

Inch					
Range	Order No.	Vernier reading	Accuracy	Base (W x T)	Remarks
0 - 6"	527-111	.001"	±.001"	3.93" x .25"	with fine adjustment
0 - 8"	527-112	.001"	±.001"	3.93" x .25"	with fine adjustment
0 - 12"	527-113	.001"	±.0015"	9.8" x .39"	with fine adjustment
0 - 24"	527-114	.001"	±.002"	9.8" x .39"	with fine adjustment
0 - 40"	527-115	.001"	±.003"	9.8" x .39"	with fine adjustment

DIMENSIONS

